

TB 9-6625-2304-35

CHANGE 1

DEPARTMENT OF THE ARMY TECHNICAL BULLETIN

CALIBRATION PROCEDURE FOR A31U12661-3, SELF-ALIGNMENT INTERFACE CONNECTION DEVICE

Headquarters, Department of the Army, Washington, DC

27 October 2004

Distribution Statement A: Approved for public release; distribution is unlimited.

TB 9-6625-2304-35, 23 March 04, is changed as follows:

1. Remove old pages and insert new pages as indicated below. New or changed material is indicated by a vertical bar in the margin of the page.

Remove Pages

9 and 10

Insert Pages

9 and 10

2. File this change sheet in front of the publication for reference purposes.

By Order of the Secretary of the Army:

Official:



JOEL B. HUDSON
*Administrative Assistant to the
Secretary of the Army*

PETER J. SCHOOMAKER

*General, United States Army
Chief of Staff*

0424402

Distribution:

To be distributed in accordance with IDN 344508 requirements for calibration procedure
TB 9-6625-2304-35.

***TB 9-6625-2304-35**

DEPARTMENT OF THE ARMY TECHNICAL BULLETIN

CALIBRATION PROCEDURE FOR A31U12661-3, SELF-ALIGNMENT INTERFACE CONNECTION DEVICE

Headquarters, Department of the Army, Washington, DC
23 March 2004

Distribution Statement A: Approved for public release; distribution is unlimited.

REPORTING OF ERRORS AND RECOMMENDING IMPROVEMENTS

You can improve this manual. If you find any mistakes or if you know of a way to improve these procedures, please let us know. Mail your letter or DA Form 2028 (Recommended Changes to Publications and Blank Forms) directly to: Commander, US Army Aviation and Missile Command, AMSAM-MMC-MA-NP, Redstone Arsenal, AL 35898-5000. A reply will be furnished to you. You may also provide DA Form 2028 information to AMCOM via e-mail, fax, or the World Wide Web. Our fax number is DSN 788-6546 or Commercial 256-842-6546. Our e-mail address is 2028@redstone.army.mil. Instructions for sending an electronic 2028 may be found at the back of this manual. For the World Wide Web, use <https://amcom2028.redstone.army.mil>.

SECTION		Paragraph	Page
	I. IDENTIFICATION AND DESCRIPTION		
	Test instrument identification	1	2
	Forms, records, and reports.....	2	2
	Calibration description	3	2
	II. EQUIPMENT REQUIREMENTS		
	Equipment required.....	4	3
	Accessories required.....	5	3
	III. CALIBRATION PROCESS		
	Preliminary instructions	6	4
	Equipment setup.....	7	4
	Dc voltage	8	5
	Ac voltage and frequency.....	9	6
	Resistance (100 Ω to 1.0 M Ω)	10	8
	Load resistance (10 to 60 m Ω).....	11	8
	Thermal converter.....	12	9
	Final procedure	13	10

*This bulletin supersedes TB 9-6625-2304-35, dated 9 May 1994, including all changes.

**SECTION I
IDENTIFICATION AND DESCRIPTION**

1. Test Instrument Identification. This bulletin provides instructions for the calibration of A31U12661-3, Self-Alignment Interface Connection Device. The Calibration and Measurements Requirements Summary (CMRS) IFTE89P630305-00, dated 11 May 1993, and TM 11-6625-3267-24&P were used as the prime data sources in compiling these instructions. The equipment being calibrated will be referred to as the TI (test instrument) throughout this bulletin.

a. Model Variations. None.

b. Time and Technique. The time required for this calibration is approximately 4 hours, using the dc and low frequency technique.

2. Forms, Records, and Reports

a. Forms, records, and reports required for calibration personnel at all levels are prescribed by TB 750-25.

b. Adjustments to be reported are designated (R) at the end of the sentence in which they appear. When adjustments are in tables the (R) follows the designated adjustment. Report only those adjustments made and designated with (R).

3. Calibration Description. TI parameters and performance specifications which pertain to this calibration are listed in table 1.

Table 1. Calibration Description

Test instrument parameters	Performance specifications	
Dc voltage	Range	Accuracy (±)
	0.09 V	450 μV
	0.90 V	4.5 mV
	9.0 V	45 mV
	18.0 V	90 mV
Frequency	Range: 20 kHz Accuracy: ±200 Hz	
Ac voltage	Range	Accuracy (±)
	1.0 V, 20 kHz	0.6 mV
	10.0 V, 20 kHz	6.0 mV
Load Resistance	Range	Accuracy (±)
	10.0 mΩ	51.0 μΩ
	20.0 mΩ	102 μΩ
	60.0 mΩ	300 μΩ
Thermal Converter	Flatness accuracy: ±1.0% Frequency range: 25 Hz to 750 kHz	

**SECTION II
EQUIPMENT REQUIREMENTS**

4. Equipment Required. Table 2 identifies the specific equipment to be used in this calibration procedure. This equipment is issued with Secondary Transfer Calibration Standards Set AN/GSM-286, or AN/GSM-705. Alternate items may be used by the calibrating activity. The items selected must be verified to perform satisfactorily prior to use and must bear evidence of current calibration. The equipment must meet or exceed the minimum use specifications listed in table 2. The accuracies listed in table 2 provide a four-to-one ratio between the standard and TI. Where the four-to-one ratio cannot be met, the actual accuracy of the equipment selected is shown in parenthesis.

5. Accessories Required. The accessories required for this calibration are common usage accessories, issued as indicated in paragraph 4 above and are not listed in this calibration procedure. The following peculiar accessories are also required for this calibration: 6 each, banana-to-pin adapters; Dc power supply, model LR-10 (LR-10).

Table 2. Minimum Specifications of Equipment Required

Common name	Minimum use specifications	Manufacturer and model (part number)
CALIBRATOR	Dc voltage output: 1.0 V Accuracy: ¹ Dc current output: 1.0 A Accuracy: ² Ac voltage capability: Output: 1.0 V Frequency: 25 Hz to 750 kHz	Fluke, Model 5720A (p/o MIS-35947)
MULTIMETER	Dc voltage: Range: 6.0 mV to 18 V Accuracy: (±%) Input: 6.0 mV ¹ 10 to 60 mV ² 90 mV to 9.0 V: .016 18 V: .0056 Ac voltage: Range: 1.0 V and 10 V Frequency: 20 kHz Accuracy: ±0.03%. Resistance: Range: 100 Ω to 1.0 MΩ Accuracy: ±0.0025% Frequency measurement: Range: 20 kHz Accuracy: ±0.25%	Hewlett-Packard, Model 3458A (3458A)

¹Combined accuracy of calibrator (1.0 V dc) and multimeter (6.0 mV dc, nominal) is ±.025%.

²Combined accuracy of calibrator (dc current) and multimeter (10 to 60 mV dc) is ±0.125%.

**SECTION III
CALIBRATION PROCESS**

6. Preliminary Instructions

a. The instructions outlined in paragraphs 6 and 7 are preparatory to the calibration process. Personnel should become familiar with the entire bulletin before beginning the calibration.

b. Items of equipment used in this procedure are referenced within the text by common name as listed in table 2.

c. Unless otherwise specified, verify the result of each test and, whenever the test requirement is not met, take corrective action before continuing with the calibration. Adjustments required to calibrate the TI are included in this procedure. Additional maintenance information is contained in TM 11-6625-3267-24&P.

d. Unless otherwise specified, all controls and control settings refer to the TI.

7. Equipment Setup

WARNING

HIGH VOLTAGE is used or exposed during the performance of this calibration. DEATH ON CONTACT may result if personnel fail to observe safety precautions. REDUCE OUTPUT(S) to minimum after each step within the performance check where applicable.

a. Open protective cover from TI when necessary to make adjustments and as instructed in text. Close cover after completing the adjustments.

b. Connect calibrator and dc power supply as shown in figure 1.

c. Set calibrator for a 28 V dc and adjust dc power supply for a 36 V dc output. Periodically monitor output of dc power supply to maintain the 36 (± 1.0) V dc.

d. Allow 1 hour for equipment warm-up before proceeding.

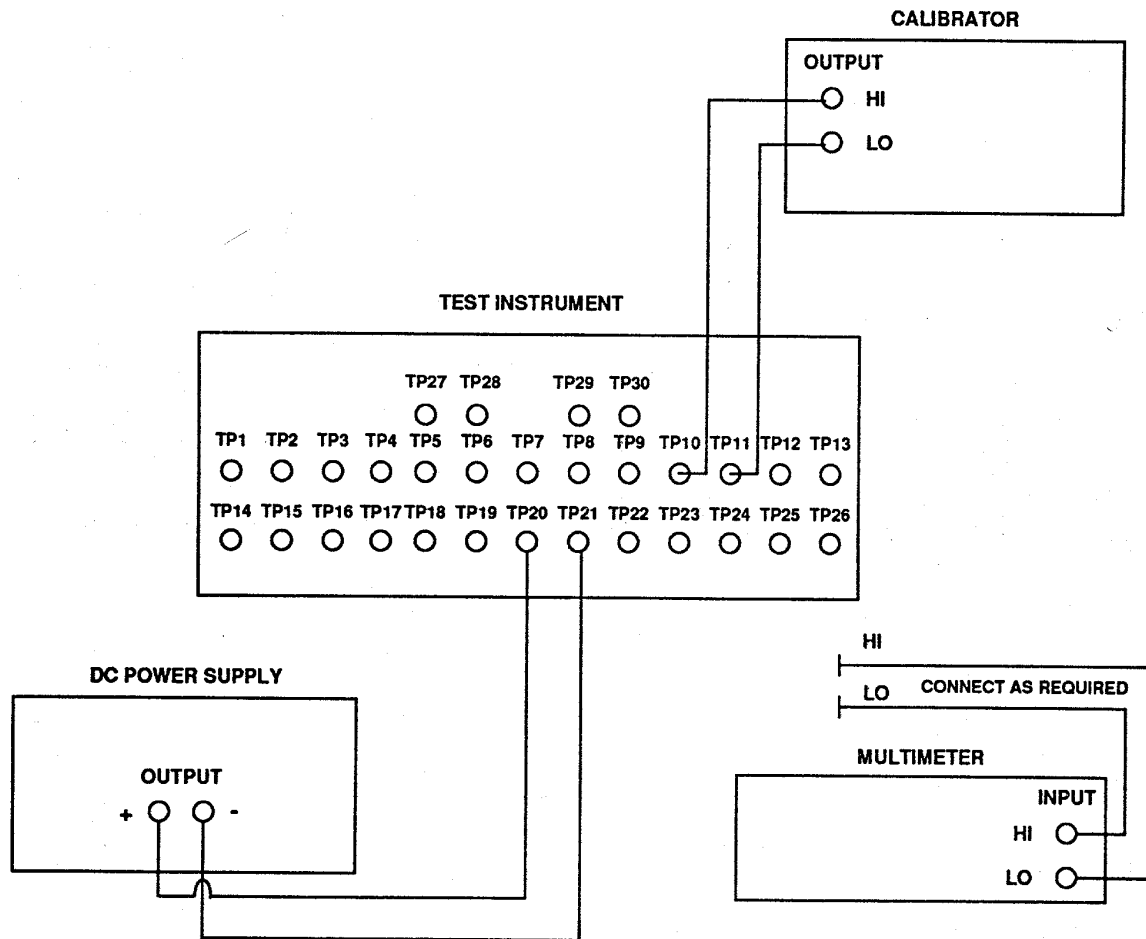

Figure 1. Dc and ac voltage.

8. Dc Voltage

a. Performance Check

- (1) Configure multimeter for most accurate dc voltage measurements.
- (2) Connect multimeter **INPUT HI** to TI TP12 and **LO** to TP23. Multimeter will indicate between 0.089550 and 0.090450 V dc.
- (3) Repeat technique of (2) above while moving multimeter **INPUT HI** test lead to each TI test point (TP) specified in table 3. Multimeter will indicate within the limits listed.

Table 3. Dc Voltage

INPUT HI to test instrument	Multimeter indications (V)	
	Min	Max
TP25	0.89550	0.90450
TP24	8.95500	9.04500
TP22	17.9100	18.0900

b. Adjustments. Ensure that dc power supply output is 36 (± 1) V dc; otherwise, no adjustments can be made.

9. Ac Voltage and Frequency

a. Performance Check

- (1) Configure multimeter for most accurate ac voltage measurements.
- (2) Connect multimeter **INPUT HI** to TI TP7 and **LO** to TP9. Multimeter will indicate between 9.9940 and 10.0060 V ac; if not, perform **b** (1) below.
- (3) Move multimeter **INPUT HI** test lead to TI TP8. Multimeter will indicate between .99940 and 1.00060 V ac; if not, perform **b** (2) below.
- (4) Press multimeter **FREQ** pushbutton.
- (5) Multimeter will indicate between 19.8 and 20.2 kHz.
- (6) Reduce calibrator and dc power supply outputs to minimum.

b. Adjustments

- (1) Adjust 10 V ac adjustment (fig. 2) for a 10.0000 V (± 1.0 mV) indication on multimeter (R).
- (2) Adjust 1 V ac adjustment (fig. 2) for a 1.00000 V (± 0.1 mV) indication on multimeter (R).

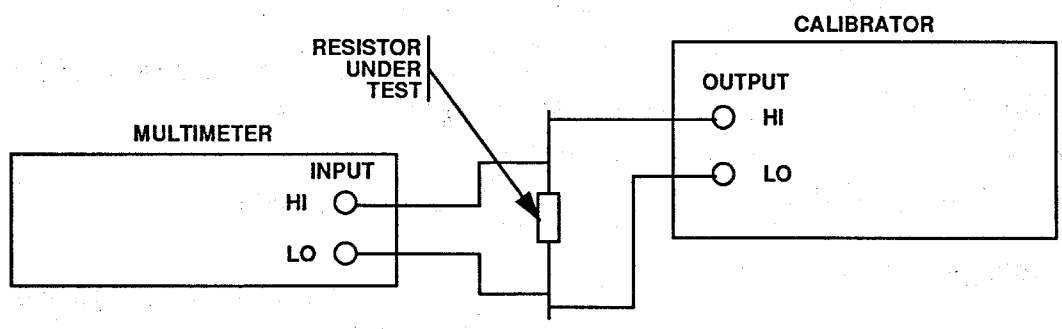
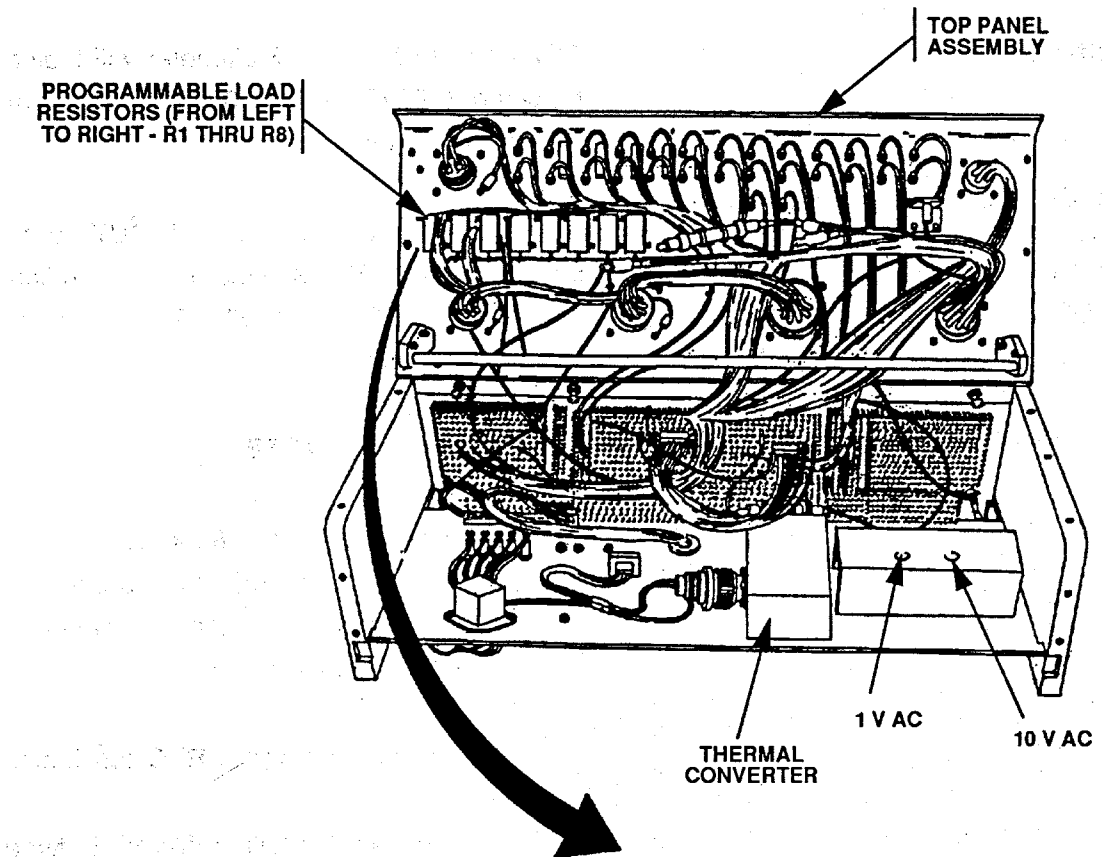

Figure 2. Load resistance and adjustments.

10. Resistance (100 Ω to 1.0 MΩ)

a. Performance Check

- (1) Disconnect all equipment from TI.
- (2) Configure multimeter for 2-wire resistance measurements.

(3) Connect multimeter **INPUT HI** and **LO** terminals to TI as specified in table 4. At each test point, set multimeter to appropriate manual range. Multimeter will indicate within the limits listed.

b. Adjustments. No adjustments can be made.

Table 4. Resistance

Connection to test instrument		Range		Multimeter indications			
HI	LO			Min		Max	
TP6	TP19	1.0	MΩ	0.99990	MΩ	1.00010	MΩ
TP5	TP18	100	kΩ	99.990	kΩ	100.010	kΩ
TP4	TP17	10	kΩ	9.9990	kΩ	10.0010	kΩ
TP3	TP16	1.0	kΩ	0.99950	kΩ	1.00050	kΩ
TP2	TP15	100	Ω	99.50	Ω	100.50	Ω

11. Load Resistance (10 to 60 mΩ)

a. Performance Check

- (1) Remove six screws and washers securing the hinged TI top panel.
- (2) Starting with R1, connect equipment as shown in figure 2.

CAUTION

The type of test leads used and improper connection of calibrator/multimeter to resistor under test can cause out-of-tolerance indications. Ensure solid contact is made as close to resistor as possible.

- (3) Configure multimeter for most accurate dc voltage measurements.
- (4) Set calibrator for a 1.0 A dc output. Multimeter will indicate between 9.9490 and 10.0510 mV.
- (5) Set calibrator output to minimum.
- (6) Move calibrator and multimeter connections to next resistor specified in table 5. Repeat technique of (4) and (5) above for R2 through R8. Multimeter will indicate within the listed limits.

b. **Adjustments.** No adjustments can be made.

Table 5. Load Resistance

Test instrument		Multimeter indications (mV dc)	
Resistor	Nominal value (mΩ)	Min	Max
R2	10.0	9.9490	10.0510
R3	20.0	19.8980	20.1020
R4	20.0	19.8980	20.1020
R5	20.0	19.8980	20.1020
R6	20.0	19.8980	20.1020
R7	20.0	19.8980	20.1020
R8	60.0	59.7000	60.3000

12. Thermal Converter

a. Performance Check

NOTE

The TI thermal converter will have to be disconnected from the internal connections (including the T-connector) before connecting as described in (1) below.

(1) Connect TI's thermal converter output (P2/J2 of TC1) (after being disconnected from internal connections) to multimeter and TI thermal converter input (P1/J1 of TC1) to calibrator.

(2) Set calibrator for a 1.0 V dc output. Allow approximately 30 minutes for thermal converter stabilization.

NOTE

Thermal converter in (2) above should be covered, so as to shield from changing air currents.

(3) Record multimeter indication; then reverse polarity of calibrator output. Record multimeter indication again. If the two indications are not equal, average them and record value as DC Reference.

(4) Set calibrator frequency to 25 Hz. Using output adjustment control, adjust calibrator amplitude for a multimeter indication equal to value recorded as Dc reference ($\pm 0.5 \mu\text{V}$). Calibration Error indication will not exceed $\pm 1.0\%$.

(5) Repeat technique of (4) above for 50 Hz, 20 kHz, 60 kHz, 175 kHz and 750 kHz. Calibrator Error indication will not exceed $\pm 1.0\%$.

b. **Adjustments.** No adjustments can be made.

TB 9-6625-2304-35

13. Final Procedure

- a. Deenergize and disconnect all equipment.
- b. Annotate and affix DA label/form in accordance with TB 750-25.

By Order of the Secretary of the Army:

Official:



JOEL B. HUDSON

*Administrative Assistant to the
Secretary of the Army*

PETER J. SCHOOMAKER

General, United States Army

Chief of Staff

0402602

Distribution:

To be distributed in accordance with the initial distribution number (IDN) 344508, requirements for calibration procedure TB 9-6625-2304-35.

Instructions for Submitting an Electronic 2028

The following format must be used if submitting an electronic 2028. The subject line must be exactly the same and all fields must be included; however, only the following fields are mandatory: 1, 3, 4, 5, 6, 7, 8, 9, 10, 13, 15, 16, 17, and 27.

From: "Whomever" whomever@redstone.army.milT
To: <2028@redstone.army.mil

Subject: DA Form 2028

1. **From:** Joe Smith
2. **Unit:** home
3. **Address:** 4300 Park
4. **City:** Hometown
5. **St:** MO
6. **Zip:** 77777
7. **Date Sent:** 19-OCT -93
8. **Pub no:** 55-2840-229-23
9. **Pub Title:** TM
10. **Publication Date:** 04-JUL-85
11. **Change Number:** 7
12. **Submitter Rank:** MSG
13. **Submitter FName:** Joe
14. **Submitter MName:** T
15. **Submitter LName:** Smith
16. **Submitter Phone:** 123-123-1234
17. **Problem:** 1
18. **Page:** 2
19. **Paragraph:** 3
20. **Line:** 4
21. **NSN:** 5
22. **Reference:** 6
23. **Figure:** 7
24. **Table:** 8
25. **Item:** 9
26. **Total:** 123
27. **Text**

This is the text for the problem below line 27.

